



INTERNATIONAL JOURNAL OF PURE AND APPLIED RESEARCH IN ENGINEERING AND TECHNOLOGY

A PATH FOR HORIZING YOUR INNOVATIVE WORK

DESIGN OF REAL TIME EMBEDDED SOLAR TRACKING

P. MADHU¹, V VISWANADHA²

1. M Tech Student, Embedded systems, Department of ECE, SIETK, Puttur, Andhra Pradesh, India.

2. Assistant Professor M.Tech , SIETK, Puttur, Andhra Pradesh, India.

Accepted Date: 24/07/2015; Published Date: 01/08/2015

Abstract: - Solar panels are devices that convert light into electricity. They are called solar after the sun because the sun is the most powerful source of the light available for use. They are sometimes called photovoltaic which means "light-electricity". Solar cells or PV cells rely on the photovoltaic effect to absorb the energy of the sun and cause current to flow between two oppositely charge layers. A solar panel is a collection of solar cells. Although each solar cell provides a relatively small amount of power, many solar cells spread over a large area can provide enough power to be useful. To get the most power, solar panels have to be pointed directly at the Sun. Renewable energy is rapidly gaining importance as an energy resource as fossil fuel prices fluctuate. One of the most popular renewable energy sources is solar energy. Solar tracking enables more energy to be generated because the solar panel is able to maintain a perpendicular profile to the sun's rays. There are three ways to increase the efficiency of a photovoltaic (PV) system.

1) The first is to increase the efficiency of the solar cell.

2) The second is to maximize the energy conversion from the solar panel.

3) Use Solar tracking system. The third method to increase the efficiency of a PV system is to employ a solar panel tracking system. As the sun moves across the sky during the day, it is advantageous to have the solar panels track the location of the sun, such that the panels are always perpendicular to the solar energy radiated by the sun. This will tend to maximize the amount of power radiated by the sun.

Keywords: PIC microcontroller, DC motor, ADC, Solar panel, LCD display.

Corresponding Author: MS. P. MADHU



PAPER-QR CODE

Access Online On:

www.ijpret.com

How to Cite This Article:

P. Madhu, IJPRET, 2015; Volume 3 (12): 200-209

INTRODUCTION

Renewable energy is rapidly gaining importance as an energy resource as fossil fuel prices fluctuate. One of the most popular renewable energy sources is solar energy. Many researches were conducted to develop some methods to increase the efficiency of Photo Voltaic systems (solar panels). One such method is to employ a solar panel tracking system. This project deals with a microcontroller based solar panel tracking system. Solar tracking enables more energy to be generated because the solar panel is always able to maintain a perpendicular profile to the sun's rays.

Development of solar panel tracking systems has been ongoing for several years now. As the sun moves across the sky during the day, it is advantageous to have the solar panels track the location of the sun, such that the panels are always perpendicular to the solar energy radiated by the sun. This will tend to maximize the amount of power absorbed by PV systems. It has been estimated that the use of a tracking system, over a fixed system, can increase the power output by 30% - 60%.

EXISTING SYSTEM:

In existing system, solar panels are stable. The solar panels are not track the sun. So during sometime only we will get maximum energy and remaining time the energy is low. So it reduces the performance of the system and also energy efficiency. So we go for another system that is Solar tracking system.

PROPOSED METHOD:

In existing system, solar panels are stable. The solar panels are not track the sun. So during sometime only we will get maximum energy and remaining time the energy is low. So it reduces the performance of the system and also energy efficiency. So we go for another system that is Solar tracking system. In this system, solar panels track the sun continuously. According to the movement of the sun, solar panels will move. So we will generate maximum electricity from solar energy. So it is the better approach to increase the performance of the system.

TECHNOLOGY:

The block representation of our project is shown below. It contains several blocks such as Microcontroller, power supply, DC motor, LDR, ADC, 2*16 LCD Display.

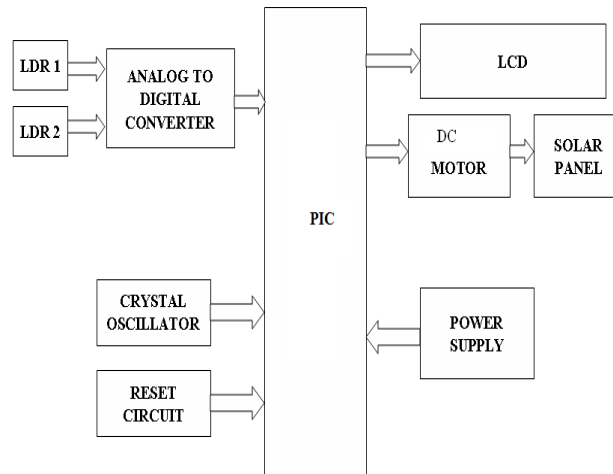

Fig : Block diagram of proposed system

Popularity of the PIC microcontrollers is due to the following factors.

1. Speed: Harvard Architecture, RISC architecture, 1 instruction cycle = 4 clock cycles.
2. Instruction set simplicity: The instruction set consists of just 35 instructions (as opposed to 111 instructions for 8051).
3. Power-on-reset and brown-out reset. Brown-out-reset means when the power supply goes below a specified voltage (say 4V), it causes PIC to reset; hence malfunction is avoided. A watch dog timer (user programmable) resets the processor if the software/program ever malfunctions and deviates from its normal operation.
4. Programmable timers and on-chip ADC.
5. Up to 12 independent interrupt sources.
6. Powerful output pin control (25 mA (max.) current sourcing capability per pin.)
7. EPROM/OTP/ROM/Flash memory option.
8. I/O port expansion capability

CPU Architecture:

The CPU uses Harvard architecture with separate Program and Variable (data) memory interface. This facilitates instruction fetch and the operation on data/accessing of variables simultaneously. Architecture of PIC microcontroller

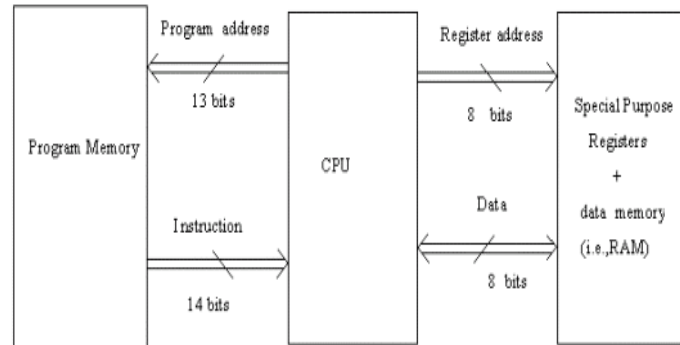
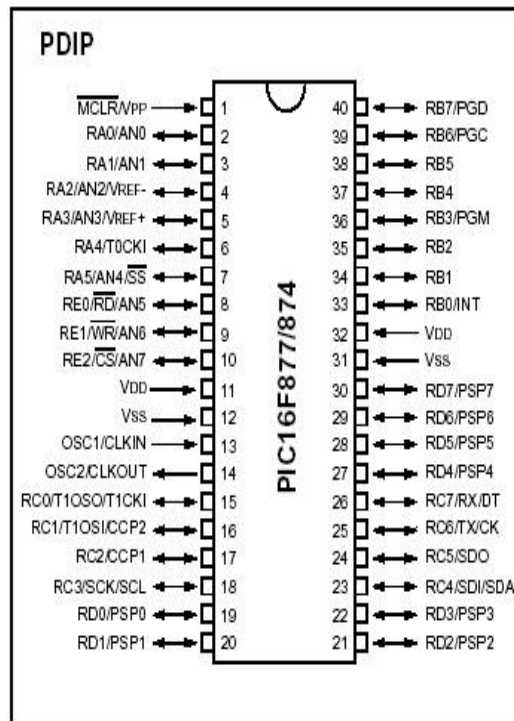

Fig. Architecture of PIC microcontroller

Basically, all PIC microcontrollers offer the following features:

- RISC instruction set with around 35 instructions
- 9 Digital I/O ports
- On-chip timer with 8-bit prescaler.
- Power-on reset
- Watchdog timer
- Power saving SLEEP mode
- Direct, indirect, and relative addressing modes
- External clock interface
- RAM data memory
- EPROM (or OTP) program memory

PIN DIAGRAM:



Pic16f877 is a 40 pin microcontroller. It has 5 ports port A, port B, port C, port D, port E. All the pins of the ports are for interfacing input output devices.

Port A: It consists of 6 pins from A0 to A5

Port B: It consists of 8 pins from B0 to B7

Port C: It consists of 8 pins from C0 to C7

Port D: It consists of 8 pins from D0 to D7

Port E: It consists of 3 pins from E0 to E2

The rest of the pins are mandatory pins these should not be used to connect input/output devices.

Pin 1 is MCLR (master clear pin) pin also referred as reset pin.

Pin 13, 14 are used for crystal oscillator to connect to generate a frequency of about 20MHz.

Pin 11, 12 and 31, 32 are used for voltage supply Vdd(+) and Vss(-)

PIC 16F877A Specification:

RAM	368 bytes
EEPROM	256 bytes
Flash Program Memory	8k words
Operating Frequency	DC to 20MHz
I/O port	Port A,B,C,D,E

Light Dependent Resistor:

LDRs or Light Dependent Resistors are very useful especially in light/dark sensor circuits. Normally the resistance of an LDR is very high, sometimes as high as 1,000,000 ohms, but when they are illuminated with light, the resistance drops dramatically.

Thus in this project, LDR plays an important role in switching on the lights in the room based on the intensity of light i.e., if the intensity of light is more (during daytime) the lights will be in off condition. And if the intensity of light is less (during nights), the lights will be switched on.

This is an example of a light sensor circuit: When the light level is low the resistance of the LDR is high. This prevents current from flowing to the base of the transistors. Consequently the LED does not light. However, when light shines onto the LDR its resistance falls and current flows into the base of the first transistor and then the second transistor. The LED glows. The preset resistor can be turned up or down to increase or decrease resistance, in this way it can make the circuit more or less sensitive.

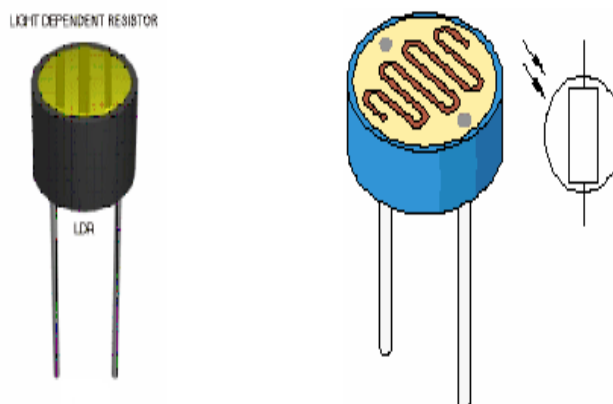

D.C Motor:

A dc motor uses electrical energy to produce mechanical energy, very typically through the interaction of magnetic fields and current-carrying conductors. The reverse process, producing electrical energy from mechanical energy, is accomplished by an alternator, generator or dynamo. Many types of electric motors can be run as generators, and vice versa. The input of a DC motor is current/voltage and its output is torque (speed).

The magnetic field in the armature and field coil causes the armature to begin to rotate. This occurs by the unlike magnetic poles attracting each other and the like magnetic poles repelling each other. As the armature begins to rotate, the commutator segments will also begin to move under the brushes. As an individual commutator segment moves under the brush connected to positive voltage, it will become positive, and when it moves under a brush connected to negative voltage it will become negative. In this way, the commutator segments continually change polarity from positive to negative. Since the commutator segments are connected to the ends of the wires that make up the field winding in the armature, it causes the magnetic field in the armature to change polarity



The DC motor has two basic parts: the rotating part that is called the armature and the stationary part that includes coils of wire called the field coils. The stationary part is also called the stator. Figure shows a picture of a typical DC motor, Figure shows a picture of a DC armature, and Fig shows a picture of a typical stator. From the picture you can see the armature is made of coils of wire wrapped around the core, and the core has an extended shaft that rotates on bearings. You should also notice that the ends of each coil of wire on the armature are terminated at one end of the armature. The termination points are called the commutator, and this is where the brushes make electrical contact to bring electrical current from the stationary part to rotatory part of the machine

SOFTWARE DESCRIPTION:

This project is implemented following software's:

- Express PCB – for designing circuit
- PIC C compiler - for compilation part
- Proteus 7 (Embedded C) – for simulation part

Express PCB:

Breadboards are great for prototyping equipment as it allows great flexibility to modify a design when needed; however the final product of a project, ideally should have a neat PCB, few cables, and survive a shake test. Not only is a proper PCB neater but it is also more durable as there are no cables which can yank loose.

Express PCB is a software tool to design PCBs specifically for manufacture by the company Express PCB (no other PCB maker accepts Express PCB files). It is very easy to use, but it does have several limitations.

1. It can be likened to more of a toy than a professional CAD program.
2. It has a poor part library (which we can work around)
3. It cannot import or export files in different formats

PIC Compiler:

PIC compiler is software used where the machine language code is written and compiled. After compilation, the machine source code is converted into hex code which is to be dumped into the microcontroller for microcontroller and this is done by the Proteus. Proteus is a programmer which itself contains a microcontroller in it other than the one which is to be programmed. This microcontroller has a program in it written in such a way that it accepts the hex file from the pic compiler and dumps this hex file into the microcontroller which is to be programmed. As the Proteus programmer requires power supply to be operated, this power supply is given from the power supply circuit designed and connected to the microcontroller in proteus. The program which is to be dumped in to the microcontroller is edited in proteus and is compiled and executed to check any errors and hence after the successful compilation of the program the program is dumped in to the microcontroller using a dumper.

It's important that you know C language for microcontroller which is commonly known as Embedded C. As we are going to use PIC Compiler, hence we also call it PIC C. The PCB, PCM, and PCH are separate compilers. PCB is for 12-bit opcodes, PCM is for 14-bit opcodes, and PCH is

for 16-bit opcode PIC microcontrollers. Due to many similarities, all three compilers are covered in this reference manual. Features and limitations that apply to only specific microcontrollers are indicated within. These compilers are specifically designed to meet the unique needs of the PIC microcontroller. This allows developers to quickly design applications software in a more readable, high-level language. When compared to a more traditional C compiler, PCB, PCM, and PCH have some limitations. As an example of the limitations, function recursion is not allowed.

This is due to the fact that the PIC has no stack to push variables onto, and also because of the way the compilers optimize the code. The compilers can efficiently implement normal C constructs, input/output operations, and bit twiddling operations. All normal C data types are supported along with pointers to constant arrays, fixed point decimal, and arrays of bits.

PIC C is not much different from a normal C program. If you know assembly, writing a C program is not a crisis. In PIC, we will have a main function, in which all your application specific work will be defined. In case of embedded C, you do not have any operating system running in there. So you have to make sure that your program or main file should never exit. This can be done with the help of simple while (1) or for (;;) loop as they are going to run infinitely.

We have to add header file for controller you are using, otherwise you will not be able to access registers related to peripherals.

```
#include <16F877A.h> // header file for PIC 16F877A//
```

Proteus:

Proteus is software which accepts only hex files. Once the machine code is converted into hex code, that hex code has to be dumped into the microcontroller and this is done by the Proteus. Proteus is a programmer which itself contains a microcontroller in it other than the one which is to be programmed. This microcontroller has a program in it written in such a way that it accepts the hex file from the pic compiler and dumps this hex file into the microcontroller which is to be programmed. As the Proteus programmer requires power supply to be operated, this power supply is given from the power supply circuit designed and connected to the microcontroller in proteus. The program which is to be dumped in to the microcontroller is edited in proteus and is compiled and executed to check any errors and hence after the successful compilation of the program the program is dumped in to the microcontroller using a dumper.

CONCLUSION:

In recent years, the generation of electricity using solar technology has seen a tremendous growth, in particular because of the economic considerations and smooth operation of the solar panels. Even though the initial costs are high, but operation costs and maintenance costs are low. Solar tracking system today offer an innovative method to track the solar insolation and provide economic compatibility of the generation of electric power where grid connections are difficult to setup and costly.

Here the tracking system is based on microcontroller with effective systematic operation and the solar panel is rotated by the dc gear motor effectively

ACKNOWLEDGEMENT:

I would like to express my gratitude to the following people for their support and guidance for the success of this paper. I would express my deep sense of gratitude to thank Mr. V. Viswanadha Associate Professor of ECE, SIETK, Puttur, Andhra Pradesh.

REFERENCES:

1. LYNN, P. A. 2011. Electricity from Sunlight: An Introduction to Photovoltaics, John Wiley & Sons.
2. HOSSAIN, E., MUHIDA, R. & ALI, A. Year. Efficiency improvement of solar cell using compound parabolic concentrator and sun tracking system. In: Electric Power Conference, 2008. EPEC 2008. IEEE Canada, 6-7 Oct. 2008 2008. 1-8.
3. ALEXANDRU, C. & POZNA, C. Year. Virtual prototype of a dual-axis tracking system used for photovoltaic panels. In: Industrial Electronics, 2008. ISIE 2008. IEEE International Symposium on, June 30 2008-July 2 2008 2008. 1598-1603.
4. ZHOU, Y. & ZHU, J. Year. Application of Fuzzy Logic Control Approach in a Microcontroller-Based Sun Tracking System. In: Information Engineering (ICIE), 2010 WASE International Conference on, 14-15 Aug. 2010 2010. 161-164.
5. KASSEM, A. & HAMAD, M. Year. A microcontroller-based multifunction solar tracking system. In: Systems Conference (SysCon), 2011 IEEE International, 4-7 April 2011 2011. 13-16.
6. Kioumars, A. H. and T. Liqiong (2011). ATmega and XBee-based wireless sensing. 5th International Conference on Automation, Robotics and Applications (ICARA), 2014.